



# ZOOMGATE

Model No ASW-AR-11



# Main Features

## High-quality material

Using high-precision SUS 304 stainless steel thick plate material, corrosion resistance, high temperature resistance, oxidation resistance, durable.

## Servo Motor

- 1.Using Servo Motor,Highly stable and efficient.
- 2.1024 signal detection points are located accurately

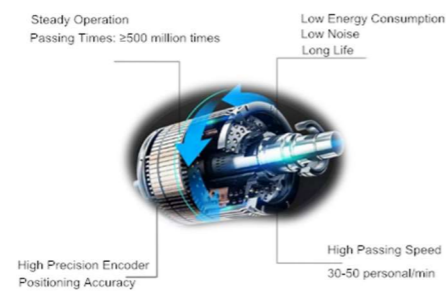

## Super Powerful CPU

1. Industrial-grade 32-bit ARM Processor.
2. Strong processing ability and fast response speed.

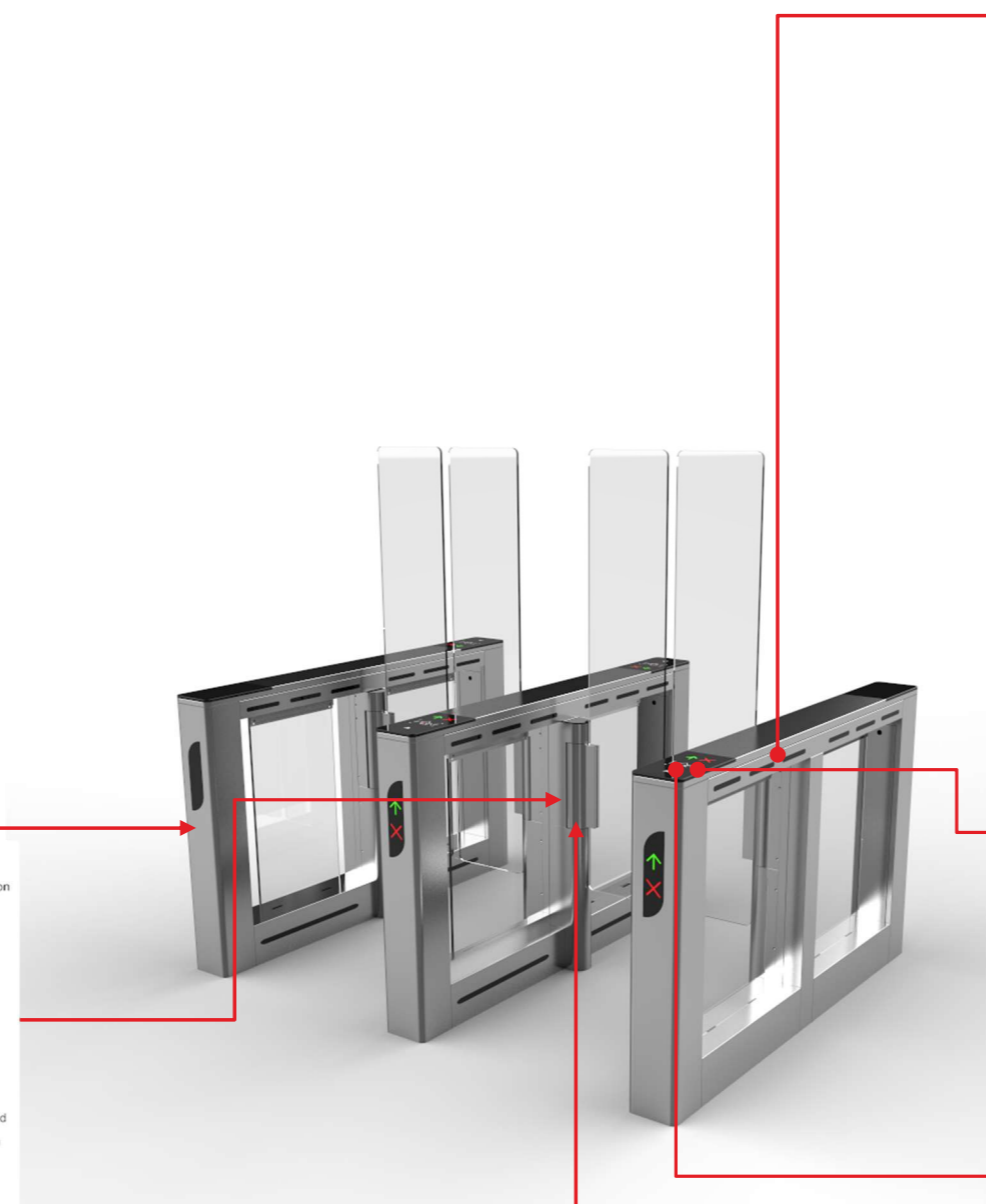
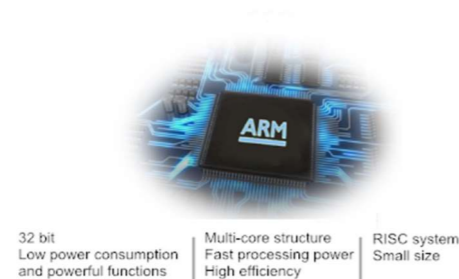

## Multiple protection function

### Anti-trailing:

Multiple sets of infrared beam monitoring can pass one person and one card to personnel,to prevent trailing and alarm prompt.

### Anti-reverse:

Precise actuarial calculation,infrared beam monitoring,reverse passage,automatic blockade of channels,voice alarm prompt.

### Anti-clip and anti-collision monitoring:

Triple safety protection mechanism to ensure the safe passage of person

## Verify Access Mode

1. Swipe Card: Support IC/ID card,NFC card, CPU card,etc.
2. Fingerprint Recognition
3. QR Code: Mobile/Paper QR code
- 4.Face Recognition



## Integrate Multiple Systems

Connected with the smart card system,access control system,consumer system,ticketing system,visitor system,static tester,etc.

## Specifications

### Structure Parameter

Material:	SUS304 brushed stainless steel (Top cover 2.0mm, whole body 1.5mm)
Swing arm available	10mm Acrylic
Size	L1600×W160×H990mm

### Technical Parameter

Passage Width	Standard 600mm, max 1100mm
Passing Speed	30-50 persons/min
Opening Speed	Adjustable, fastest 0.3s
Working Temperature	-20°C to +70°C
Mean Cycles Between Failure	10 million times
IP Rating	IP42

### Electric Parameter

Voltage	AC110V/AC220V±10% 50-60Hz
Operating Power	Single Core 100w, dual core 200w
Driving Motor	Servo motor
Method of position	Motor + clutch + encoder
Communication Interface	RS485, TCP/IP interface
Number of Sensor	12 pairs

## Dimension

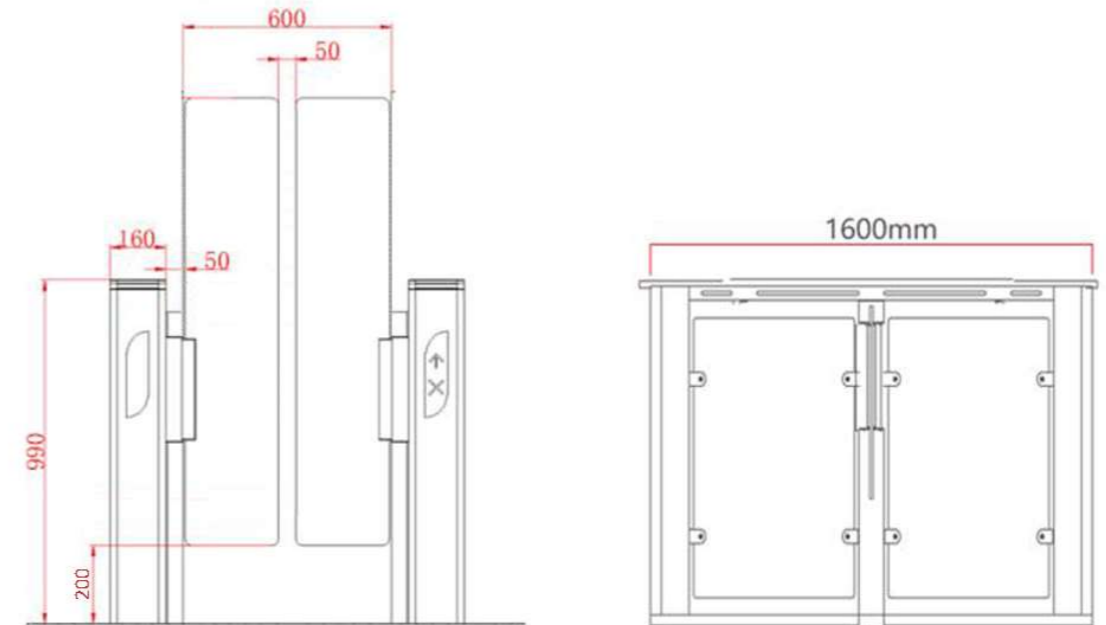

## Application

Office and administrative buildings  
Ministries and public buildings  
Banks and financial institutions  
Industrial installations  
Residential areas  
Schools, colleges and universities

# ZOOM TECH PTE LTD

---

 68 Senoko Road Singapore 758128

 +65 6365 4715

 +65 6482 3395

 [info@zoomtech.com.sg](mailto:info@zoomtech.com.sg)

 [www.zoomtech.com.sg](http://www.zoomtech.com.sg)